

**SPECIFICATION  
FOR  
LCD Module  
CFAF240320K-T-TS**

<b>MODULE:</b>	<b>CFAF240320K-T-TS</b>
<b>CUSTOMER:</b>	

<b>REV</b>	<b>DESCRIPTION</b>	<b>DATE</b>
<b>1</b>	<b>FIRST ISSUE</b>	<b>2008.10.28</b>

	<b>INITIAL</b>	<b>DATE</b>
<b>APREPARED BY</b>		<b>2008.10.28</b>
<b>CHECKED BY</b>		
<b>APPROVED BY</b>		

<b>CUSTOMER</b>	<b>INITIAL</b>	<b>DATE</b>
<b>APPROVED BY</b>		

## Revision History

Data	Rev. No.	Page	Summary
2008.10.28	1		FIRST ISSUE

PRELIMINARY

## Contents

### General Description

1. Optical Characteristics
2. Electrical Characteristics
3. Block Diagram
4. Outline dimension
5. Input Terminal Pin Assignment
6. Operating Principle & Methods
7. Reset Timing
8. Reliability Test Result
9. Cautions and Handling Precautions

PRELIMINARY

## General Description

### \* Description

This is a color active matrix TFT (Thin Film Transistor) LCD (liquid crystal display) that uses amorphous silicon TFT as a switching device. This model is composed of a Transmissive type TFT-LCD Panel, driver circuit, back-light unit. The resolution of a 2.4" TFT-LCD contains 240 x 320 pixels, and can display up to 262K colors.

### \* Features

- Low Input Voltage: VCC: 2.8V
- Display Colors of TFT LCD: 262K colors
- CPU Interface: 8080 parallel 8/9/16/18 bit
- Internal Power Supply Circuit.

General Information Items	Specification	Unit	Note
	Main Panel		
Display area(AA)	36.72(H) *48.96(V) (2.4 inch)	mm	-
Driver element	a-Si TFT active matrix	-	-
Display colors	262K	colors	-
Number of pixels	240(RGB) *320	dots	-
Pixel arrangement	RGB vertical stripe	-	-
Pixel pitch	0.153(H) *0.153(V)	mm	-
Viewing angle	12	o'clock	-
Drive IC	SPFD5408B	-	-
Display mode	Transmissive/ Normally White	-	-
Operating temperature	-20~+70	°C	-
Storage temperature	-30~+80	°C	-

### \* Mechanical Information

Item		Min.	Typ.	Max.	Unit	Note
Module size	Horizontal(H)	-	42.72	-	mm	-
	Vertical(V)	-	60.26	-	mm	-
	Depth(D)	-	2.7	-	mm	-
Weight		-	TBD	-	g	-

# 1. Optical Characteristics

The following items are measured under stable conditions. The optical characteristics should be measured in a dark room or equivalent state

(Note1 · Note2)

(Using CPT LC+ EWV Polarizer+Corresponding Backlight, reference only)

ITEM		SYMBOL	CONDITION	MIN.	TYP.	MAX.	UNIT	REMARK
Transmittance		T		4.5	5		%	
Contrast Ratio		CR	*1)		(300)	-	--	Note 3
Response Time		Tr+ Tf	*3)	-	(30)	(40)	ms	Note 4
Viewing Angle	Vertical	$\theta$ *2)	CR $\geq$ 10	(45)	(60)	-		
				(35)	(50)	-		Note 5
	Horizontal	$\phi$ *2)		(50)	(65)	-		
				(50)	(65)	-		
Color Filter Chromacicity	White	x y Y	$\theta = \phi = 0^\circ$	0.288	0.308	0.328		
				0.322	0.342	0.362		Note 6
				27.8	30.8	33.8		
	Red	x y Y	$\theta = \phi = 0^\circ$	0.633	0.653	0.673		
				0.311	0.331	0.351		
				15.4	18.4	21.4		
	Green	x y Y	$\theta = \phi = 0^\circ$	0.291	0.311	0.331		
				0.554	0.574	0.594		
				55.0	59.0	63.0		
	Blue	x y Y	$\theta = \phi = 0^\circ$	0.114	0.134	0.154		
				0.114	0.134	0.154		
				12.0	15.0	18.0		
NTSC				-	61	-	%	

Note 1.Ambient condition : 25°C ±2°C , 60±10%RH , under 10 Lux in the darkroom °

Note 2.Measure device : BM-5A (TOPCON) , viewing cone= 1° , I=20mA °

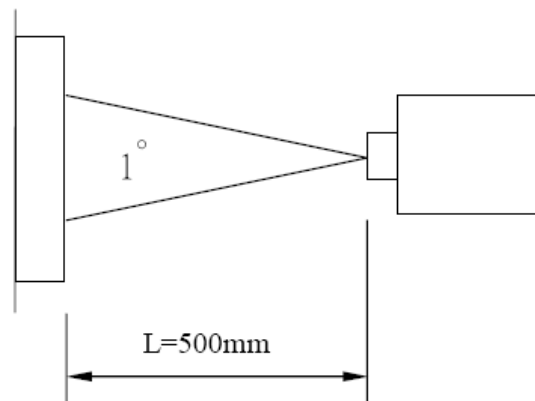

Note 3. Definition of Contrast Ratio :

$$CR = \text{White Luminance (ON)} / \text{Black Luminance (OFF)}$$

Note 4. Definition of response time : The response time is defined as the time interval between the 10% and 90% amplitudes.

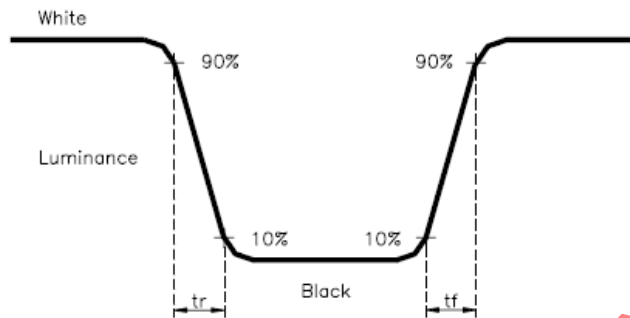

Note 5. Definition of view angle( $\theta$  ,  $\psi$ ) :

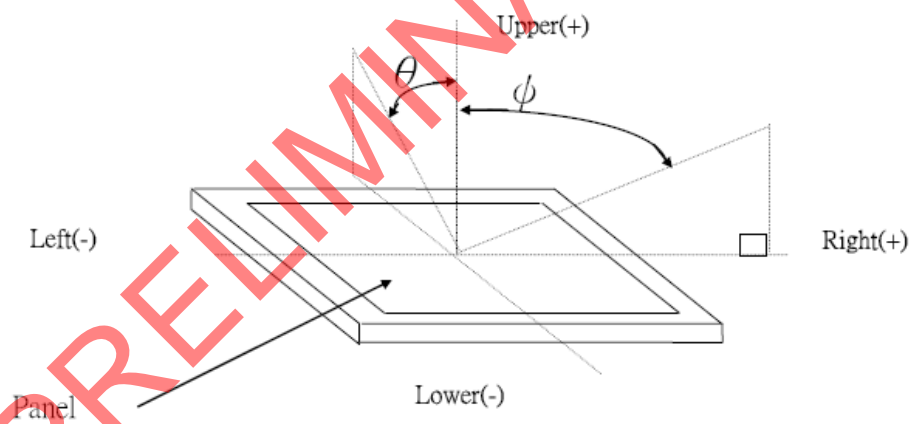

Note 6. Light source: C light

## 2. Electrical Characteristics

### 2.1 Absolute Maximum Rating (Ta=25 VSS=0V)

Characteristics	Symbol	Min.	Typ.	Max.	Unit	Note
System voltage	VCC	-0.3	-	+ 4.6	V	-
Supply voltage (Digital)	IOVCC	-0.3	-	+ 4.6	V	-
Supply voltage (Logic)	IOVCC	-0.3	-	+ 4.6	V	-
Operating temperature	T <sub>OP</sub>	-20	-	+ 70	°C	1,
Storage temperature	T <sub>ST</sub>	-30	-	+ 80	°C	2

Note1: Background color changes slightly depending on ambient temperature. This phenomenon is reversible. Ta70°C: 75%RH max

Ta>70°C: absolute humidity must be lower than the humidity of 75%RH at 70°C

Note2: Ta at -30°C will be <48hrs, at 80°C will be <120hrs

### 2.2 DC Electrical Characteristics

Characteristics	Symbol	Min.	Typ.	Max.	Unit	Note
System voltage	VCC	2.5	-	3.3	V	-
Digital & Logic operation Supply voltage	IOVCC	1.65	-	3.3	V	-
Normal mode Current consumption	VCC <sub>I</sub>	-	5	-	mA	-
Sleep-in mode Current consumption	VCC <sub>I</sub>	-	10	-	uA	-
Level input voltage	V <sub>IH</sub>	0.8 IOVCC	-	IOVCC	V	-
	V <sub>IL</sub>	GND	-	0.2 IOVCC	V	-
Level output voltage	V <sub>OH</sub>	0.8 IOVCC	-	IOVCC	V	-
	V <sub>OL</sub>	GND	-	0.2 IOVCC	V	-

### 2.3 LED Backlight Characteristics

The back-light system is edge-lighting type with 4chips White LED in parallel

Item	Symbol	Min.	Typ.	Max.	Unit	Note
Forward Current	I <sub>F</sub>	-	60	-	mA	-
Forward Voltage	V <sub>F</sub>	-	3.2	-	V	-
LCM Luminance	L <sub>V</sub>	-	180	-	cd/m <sup>2</sup>	I <sub>B</sub> =60mA
Uniformity	AV <sub>g</sub>	80	-	-	%	-

### 3. Block Diagram

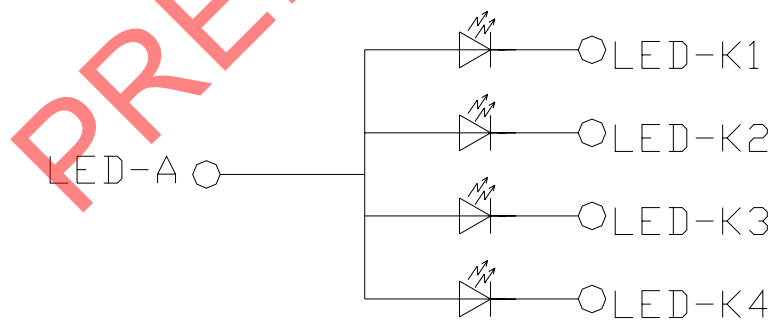
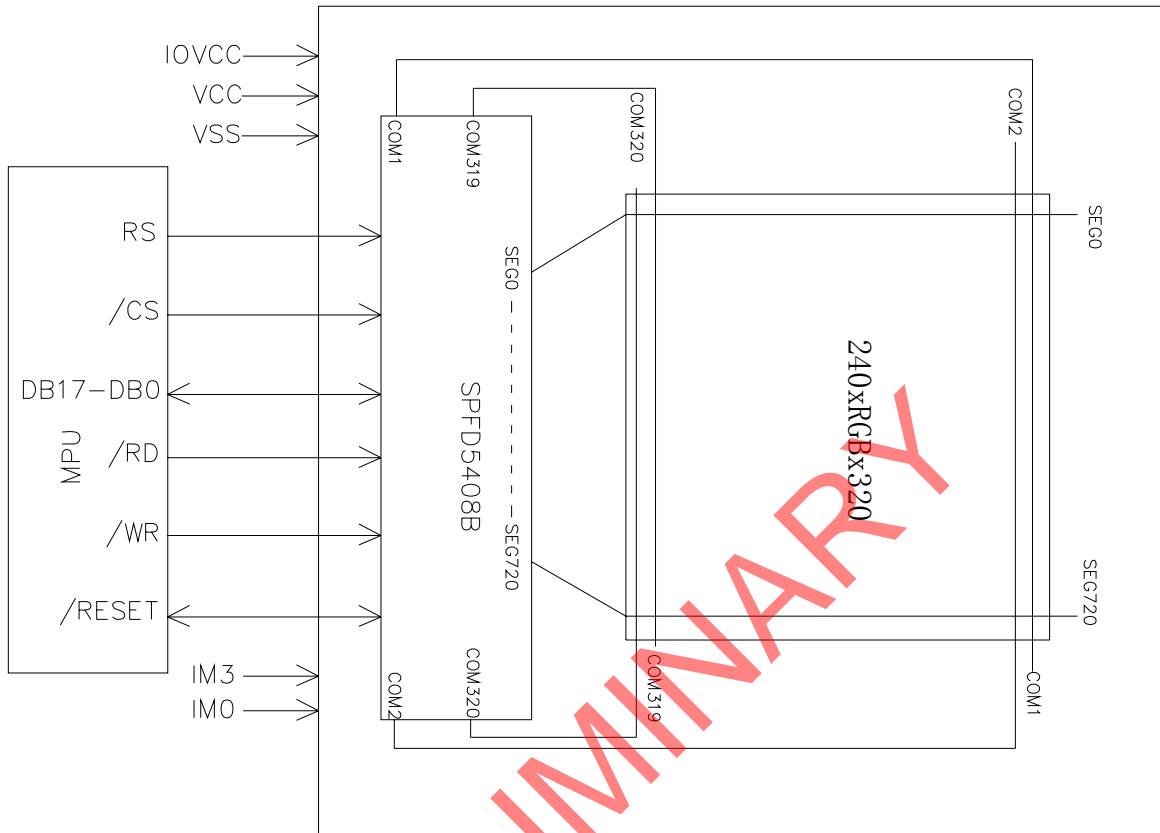



## Input terminal Pin Assignment

Pin NO.	Symbol	Level	Function
1	DB0	H/L	DATA BUS DB0
2	DB1	H/L	DATA BUS DB1
3	DB2	H/L	DATA BUS DB2
4	DB3	H/L	DATA BUS DB3
5	GND	L	GND
6	IOVCC	H	POWER SUPPLY
7	/CS	H/L	Chip select input pin
8	RS	H/L	A register select signal
9	/WR	H/L	Write enable clock input pin
10	/RD	H/L	Read enable clock input pin
11	IM0	H/L	Interface selected pin
12	X+		X+ for resistive touch panel
13	Y+		Y+ for resistive touch panel
14	X-		X- for resistive touch panel
15	Y-		Y- for resistive touch panel
16	LED-A	H	Backlight+
17	LED-K1	L	Backlight-
18	LED-K2	L	Backlight-
19	LED-K3	L	Backlight-
20	LED-K4	L	Backlight-
21	IM3	H/L	Interface selected pin
22	DB4	H/L	DATA BUS DB4
23	DB10	H/L	DATA BUS DB10
24	DB11	H/L	DATA BUS DB11
25	DB12	H/L	DATA BUS DB12
26	DB13	H/L	DATA BUS DB13
27	DB14	H/L	DATA BUS DB14
28	DB15	H/L	DATA BUS DB15
29	DB16	H/L	DATA BUS DB16
30	DB17	H/L	DATA BUS DB17
31	/RESET	H/L	HARDWARE RESET PIN
32	VCI	H	POWER SUPPLY
33	IOVCC	H	POWER SUPPLY
34	GND	L	GND
35	DB5	H/L	DATA BUS DB5
36	DB6	H/L	DATA BUS DB6
37	DB7	H/L	DATA BUS DB7

INTEFACE MODE

IM3=0 IM0=0	80-SYSTEM 16-BIT INTERFACE	USE PINS DB17-DB10, DB7-0
IM3=0 IM0=1	80-SYSTEM 8-BIT INTERFACE	USE PINS DB17-DB10
IM3=1 IM0=0	80-SYSTEM 18-BIT INTERFACE	USE PINS DB17-0 (NOT SUPPORTED)
IM3=1 IM0=1	80-SYSTEM 9-BIT INTERFACE	USE PINS DB17-9 (NOT SUPPORTED)

NOTE: DB17-0 must connect to the IOVCC or GND when not in use.

## 6. Operating Principle & Methods

Please refer to SPFD5408B datasheet for more details.

80-System Bus operation Interface Timing Characteristics (18-/16-bit interface)

Normal write operation (HWN=0 OR 1), IOVCC=1.65V~3.30V.

Item	Symbol	Unit	Min.	Typ.	Max.	
Bus cycle time	Write	tCYCW	ns	125	-	-
	Read	tCYCR	ns	450	-	-
Write low-level pulse width	PWLW	ns	45	-	-	
Read low-level pulse width	PWLR	ns	170	-	-	
Write high-level pulse width	PWHW	ns	70	-	-	
Read high-level pulse width	PWHR	ns	250	-	-	
Write/Read rise/ fall time	tWRr, WRf	ns	-	-	25	
Setup time	Write (RS to CS*, WR*)	tAS	ns	0	-	-
	Read (RS to CS*, RD*)		ns	10	-	-
Address Hold Time	tAH	ns	2	-	-	
Write data setup time	tDSW	ns	25	-	-	
Write data hold time	tH	ns	10	-	-	
Read data delay time	tDDR	ns	-	-	150	
Read data hold time	tDHR	ns	5	-	-	

## 7. INITIAL CODE

Step	Register Address	Register Value	Note
1	R00h	0x0001h	
2	R01h	0x0000h	
3	R02h	0x0701h	
4	R03h	0xD010h	
5	R04h	0x0000h	
6	R08h	0x0207h	
7	R09h	0x0000h	
8	R0Ah	0x0000h	
9	R0Ch	0x0000h	
10	R0Dh	0x0000h	
11	R0Fh	0x0000h	
12	R07h	0x0101h	
13	R10h	0x10B0h	
14	R11h	0x0007h	
15	R17h	0x0001h	
16	R12h	0x013Bh	
17	R13h	0x0B00h	
18	R29h	0x0012h	
19	R2Ah	0x0095h	
20	R50h	0x0000h	
21	R51h	0x00EFh	
22	R52h	0x0000h	
23	R53h	0x013Fh	
24	R60h	0x2700h	
25	R61h	0x0001h	
26	R6Ah	0x0000h	
27	R80h	0x0000h	
28	R81h	0x0021h	
29	R82h	0x0061h	
30	R83h	0x0173h	
31	R84h	0x0000h	
32	R85h	0x0000h	
33	R90h	0x0013h	
34	R92h	0x0000h	
35	R93h	0x0103h	
36	R95h	0x0110h	
37	R97h	0x0000h	
38	R98h	0x0000h	
39	RF0h	0x5408h	
40	RF3h	0x0010h	
41	RF4h	0x0011h	
42	RF0h	0x0000h	
43	R07h	0x0173	

Note: This initial code is not including Gamma setting. Please contact Orise Technology for desired Gamma setting.

## 8. Reliability Test Result

### 8.1 Condition

Item	Condition	Sample Size	Test Result	Note
Low Temperature Operating Life test	-20 °C, 96HR	3ea	pass	-
Thermal Humidity Operating Life test	40 °C, 90%RH, 96HR	3ea	pass	-
Temperature Cycle ON/OFF test	-20 °C ↔ 70 °C, ON/OFF, 20CYC	3ea	pass	(1)
High Temperature Storage test	80 °C, 96HR	3ea	pass	-
Low Temperature Storage test	- 30 °C, 96HR	3ea	pass	-
Thermal Shock Resistance	The sample should be allowed to stand the following 5 cycles of operation: TSTL for 30 minutes -> normal temperature for 5 minutes -> TSTH for 30 minutes -> normal temperature for 5 minutes, as one cycle, then taking it out and drying it at normal temperature, and allowing it stand for 24 hours	3ea	pass	
Box Drop Test	1 Corner 3 Edges 6 faces, 66cm(MEDIUM BOX)	1box	pass	-

Note (1) ON Time over 10 seconds, OFF Time under 10 seconds

## 9. Cautions and Handling Precautions

### 9.1 Handling and Operating the Module

- (1) When the module is assembled, it should be attached to the system firmly. Do not warp or twist the module during assembly work.
- (2) Protect the module from physical shock or any force. In addition to damage, this may cause improper operation or damage to the module and back-light unit.
- (3) Note that polarizer is very fragile and could be easily damaged. Do not press or scratch the surface.
- (4) Do not allow drops of water or chemicals to remain on the display surface. If you have the droplets for a long time, staining and discoloration may occur.
- (5) If the surface of the polarizer is dirty, clean it using some absorbent cotton or soft cloth.
- (6) The desirable cleaners are water, IPA (Isopropyl Alcohol) or Hexane. Do not use ketone type materials (ex. Acetone), Ethyl alcohol, Toluene, Ethyl acid or Methyl chloride. It might permanent damage to the polarizer due to chemical reaction.
- (7) If the liquid crystal material leaks from the panel, it should be kept away from the eyes or mouth. In case of contact with hands, legs, or clothes, it must be washed away thoroughly with soap.
- (8) Protect the module from static; it may cause damage to the CMOS ICs.
- (9) Use finger-stalls with soft gloves in order to keep display clean during the incoming inspection and assembly process.
- (10) Do not disassemble the module.
- (11) Protection film for polarizer on the module shall be slowly peeled off just before use so that the electrostatic charge can be minimized.
- (12) Pins of I/F connector shall not be touched directly with bare hands.
- (13) Do not connect, disconnect the module in the "Power ON" condition.
- (14) Power supply should always be turned on/off by the item 6.1 Power On Sequence & 6.2 Power Off Sequence

### 9.2 Storage and Transportation.

- (1) Do not leave the panel in high temperature, and high humidity for a long time.  
It is highly recommended to store the module with temperature from 0 to 35 °C and relative humidity of less than 70%
- (2) Do not store the TFT-LCD module in direct sunlight.
- (3) The module shall be stored in a dark place. When storing the modules for a long time, be sure to adopt effective measures for protecting the modules from strong ultraviolet radiation, sunlight, or fluorescent light.
- (4) It is recommended that the modules should be stored under a condition where no condensation is allowed. Formation of dewdrops may cause an abnormal operation or a failure of the module. In